

SINCE 1889



## Water Purifier, Auto Still

Model

# WS 200/220

### Instruction Manual

- First Edition -

- Thank you for purchasing " Auto Still, WS Series" of Yamato Scientific Co., Ltd.
- To use this unit properly, read this "Instruction Manual" thoroughly before using this unit. Keep this instruction manual around this unit for referring at anytime.

**⚠ WARNING!**

Carefully read and thoroughly understand the important warning items described in this manual before using this unit.

**Yamato Scientific Co. LTD.**



# Contents

---

◆ <b>Cautions in Using with Safety</b> .....	<b>1</b>
• Explanation.....	1
• Table of Illustrated Symbols .....	2
• Fundamental Matters of “WARNING!” and “CAUTION!” .....	3
◆ <b>Before Using this unit</b> .....	<b>4</b>
• Requirements for Installation.....	4
◆ <b>Description and Function of Each Part</b> .....	<b>7</b>
• Main Unit .....	7
• Control Panel.....	9
• Piping System View.....	10
◆ <b>Installation/Operation Method</b> .....	<b>11</b>
• Connecting the Water Supply Hose .....	11
• Connecting the Drain Hose .....	12
• Operation Preparation .....	12
• Operation Method.....	12
◆ <b>Handling Precautions</b> .....	<b>13</b>
◆ <b>Maintenance Method</b> .....	<b>15</b>
• Daily Inspection and Maintenance .....	15
• Washing Distiller.....	16
• Washing Method .....	18
• Replacement of Hose.....	19
• Replacement of Heater .....	20
◆ <b>Long storage and disposal</b> .....	<b>21</b>
• When not using this unit for long term / When disposing .....	21
◆ <b>In the Event of Failure</b> ... ..	<b>22</b>
◆ <b>After Service and Warranty</b> .....	<b>23</b>
◆ <b>Specification</b> .....	<b>24</b>
◆ <b>Wiring Diagram</b> .....	<b>25</b>
◆ <b>Replacement Parts Table</b> .....	<b>26</b>
◆ <b>Reference</b> .....	<b>27</b>
• List of Dangerous Substances .....	27



## Explanation

### MEANING OF ILLUSTRATED SYMBOLS

#### Illustrated Symbols

Various symbols are used in this safety manual in order to use the unit without danger of injury and damage of the unit. A list of problems caused by ignoring the warnings and improper handling is divided as shown below. Be sure that you understand the warnings and cautions in this manual before operating the unit.

---

---

 **WARNING!** If the warning is ignored, there is the danger of a problem that may cause a serious accident or even fatality.

 **CAUTION!** If the caution is ignored, there is the danger of a problem that may cause injury/damage to property or the unit itself.

---

---

#### Meaning of Symbols



This symbol indicates items that urge the warning (including the caution). A detailed warning message is shown adjacent to the symbol.



This symbol indicates items that are strictly prohibited. A detailed message is shown adjacent to the symbol with specific actions not to perform.



This symbol indicates items that should be always performed. A detailed message with instructions is shown adjacent to the symbol.

# Cautions in Using with Safety

## Table of Illustrated Symbols

### Warning



Warning,  
generally



Warning,  
high voltage



Warning,  
high temperature



Warning,  
drive train



Warning,  
explosive

### Caution



Caution,  
generally



Caution,  
electrical shock



Caution,  
scald



Caution,  
no road heating



Caution,  
not to drench



Caution,  
water only



Caution,  
deadly poison

### Prohibit



Prohibit,  
generally



Prohibit,  
inflammable



Prohibit,  
to disassemble



Prohibit,  
to touch

### Compulsion



Compulsion,  
generally



Compulsion,  
connect to the  
grounding  
terminal



Compulsion,  
install on a flat  
surface



Compulsion,  
disconnect the  
power plug



Compulsion,  
periodical  
inspection

## Cautions in Using with Safety

### Fundamental Matters of “WARNING!” and “CAUTION!”

#### **WARNING!**

##### **Do not use this unit in an area where there is flammable or explosive gas**

Never use this unit in an area where there is flammable or explosive gas. This unit is not explosion-proof. An arc may be generated when the power switch is turned on or off, and fire/explosion may result. (Refer to page27 “List of Dangerous Substances”.)

##### **Always ground this unit**

Always ground this unit on the power equipment side in order to avoid electrical shock due to a power surge.

##### **If a problem occurs**

If smoke or strange odor should come out of this unit for some reason, turn off the power key right away, and then turn off the circuit breaker and the main power. Immediately contact a service technician for inspection. If this procedure is not followed, fire or electrical shock may result. Never perform repair work yourself, since it is dangerous and not recommended.

##### **Do not use the power cord if it is bundled or tangled**

Do not use the power cord if it is bundled or tangled. If it is used in this manner, it can overheat and fire may be caused.

##### **Do not process, bend, wring, or stretch the power cord forcibly**

Do not process, bend, wring, or stretch the power cord forcibly. Fire or electrical shock may result.

##### **Substances that can not be used**

Never use explosive substances, flammable substances and substances that include explosive or flammable ingredients in this unit. Explosion or fire may occur.

##### **Do not disassemble or modify this unit**

Do not disassemble or modify this unit. Fire or electrical shock or failure may be caused.

#### **CAUTION!**

##### **During a thunder storm**

During a thunderstorm, turn off the power key immediately, then turn off the circuit breaker and the main power. If this procedure is not followed, fire or electrical shock may be caused.

## Requirements for Installation

### **WARNING!**

#### 1. Always ground this unit



- Connect the power plug to a receptacle with grounding connectors.



- Do not forget to ground this unit, to protect you and the unit from electrical shock in case of power surge. Choose a receptacle with grounding connectors as often as possible.
- Do not connect the grounding wire to a gas pipe, or by means of a lightning rod or telephone line. A fire or electrical shock will occur.

#### 2. Choose a proper place for installation



- Do not install this unit in a place where:
  - ◆ Rough or dirty surface.
  - ◆ Flammable gas or corrosive gas is generated.
  - ◆ Ambient temperature exceeds 35°C.
  - ◆ Ambient temperature fluctuates violently.
  - ◆ There is direct sunlight.
  - ◆ There is excessive humidity and dust.
  - ◆ There is a constant vibration.



- Install this unit on a stable place with the space as shown below. This unit should be installed horizontally by using adjusters on the four corners.

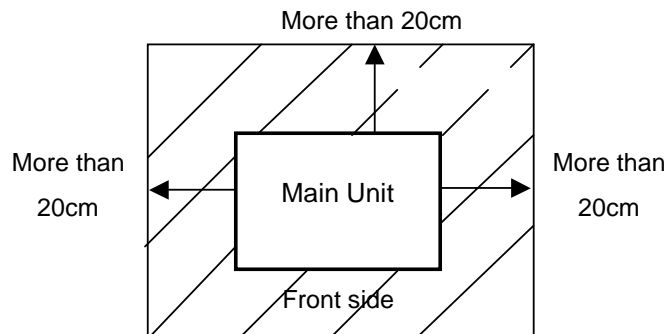



## Requirements for Installation

### 3. Do not use this unit in an area where there is flammable or explosive gas



- Never use this unit in an area where there is flammable or explosive gas. This unit is not explosion-proof. An arc may be generated when the power switch is turned ON or OFF, and fire/explosion may result. (To know about flammable or explosive gas, refer to page27 “List of Dangerous Substances”.)

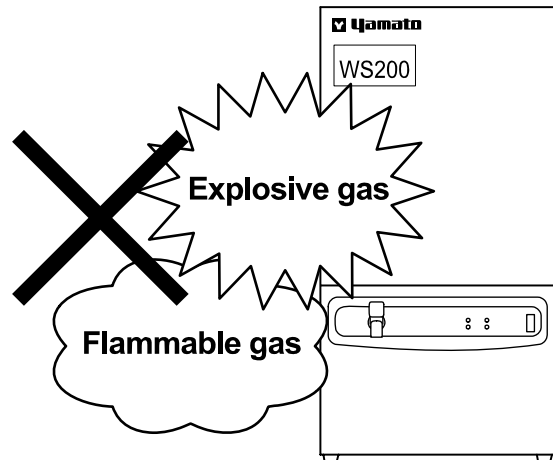

### 4. Do not modify



- Modification of this unit is strictly prohibited. This could cause a failure.

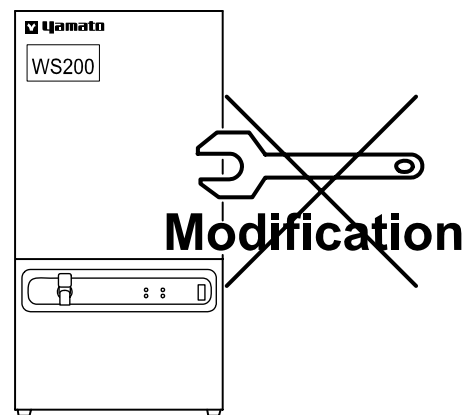

### 5. Installation on horizontal surface



- Set this unit to the flattest place. Not setting this unit with its 4 legs covered with rubber contacted to the setting place surface evenly could cause the vibration or noise, or cause the unexpectible trouble or malfunction.

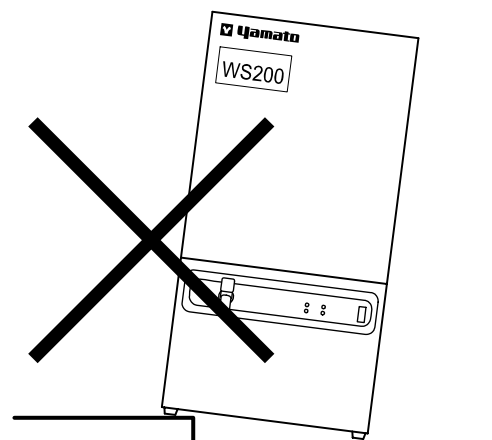

## Requirements for Installation

### **CAUTION!**

#### 6. Choose a correct power distribution board or receptacle



- Choose a correct power distribution board or receptacle that meets the unit's rated electric capacity.

**Electric capacity:**    WS200: AC100 V, 15A  
                                      WS220: AC100 V, 15A

**NOTE)**

There could be the case that the unit does not run even after turning ON the power. Inspect whether the voltage of the main power is lowered than the specified value, or whether other device(s) uses the same power line of this unit. If the phenomena might be found, change the power line of this unit to the other power line.

#### 7. Before/after installing



- It may cause injure to a person if this unit falls down or moves by the earthquake and the impact. etc..To prevent, take measures that the unit cannot fall down, and not install to busy place.

#### 8. Handling of power code



- Do not entangle the power cord. This will cause overheating and possibly a fire.
- Do not bend or twist the power cord, or apply excessive tension to it. This may cause a fire and electrical shock.
- Do not lay the power cord under a desk or chair, and do not allow it to be pinched in order to prevent it from being damaged and to avoid a fire or electrical shock.
- Keep the power cord away from any heating equipment such as a room heater. The cord's insulation may melt and cause a fire or electrical shock.



- If the power cord becomes damaged (wiring exposed, breakage, etc.), immediately turn off the power at the rear of this unit and shut off the main supply power. Then contact your nearest dealer for replacement of the power cord. Leaving it may cause a fire or electrical shock.
- Connect the power plug to the outlet which is supplied appropriate power and voltage.

# Description and Function of Each Part

## Main Unit

### WS200

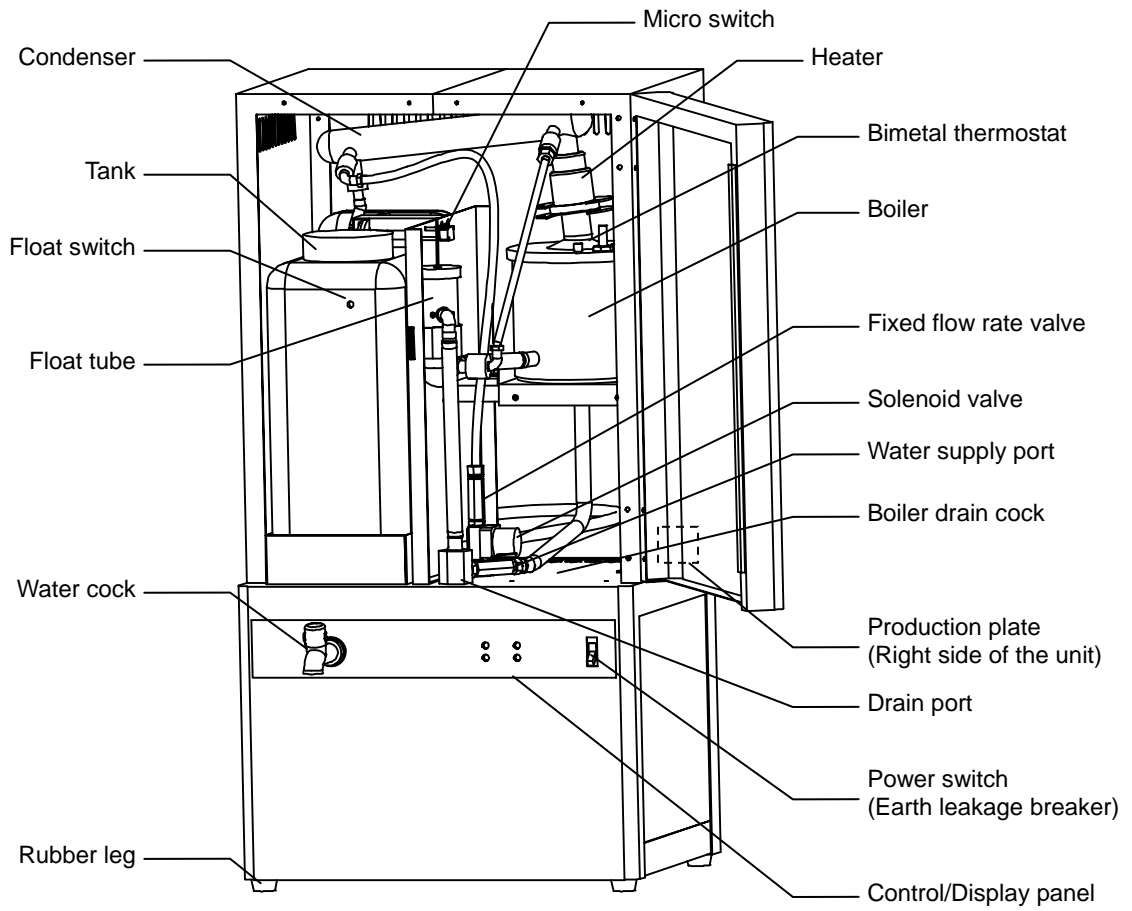

### Rear view (common to WS200/220)

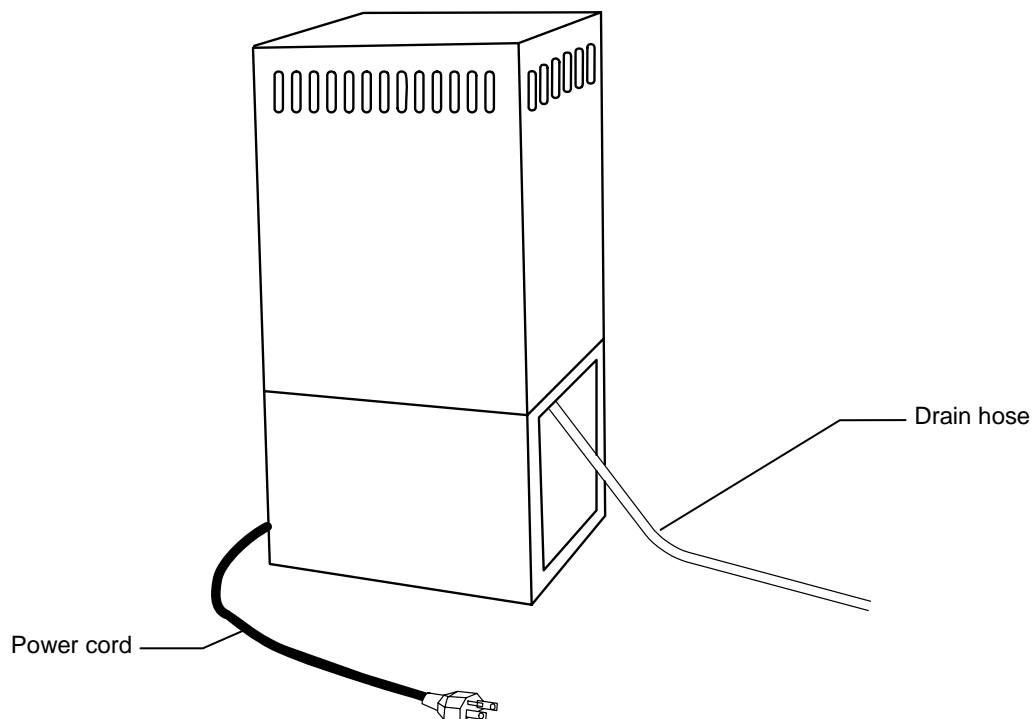

# Description and Function of Each Part

## Main Unit

WS220

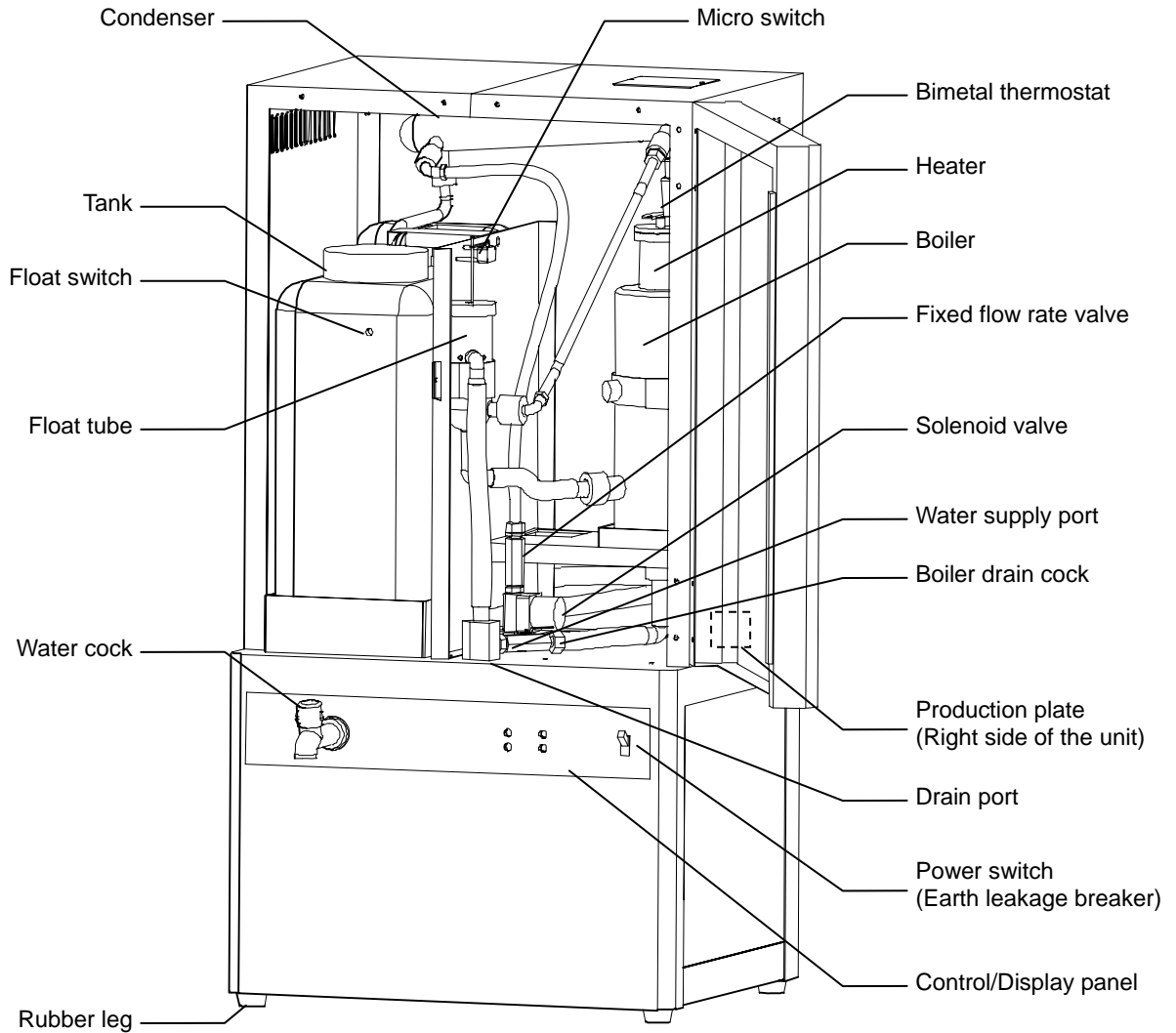

# Description and Function of Each Part

## Control Panel

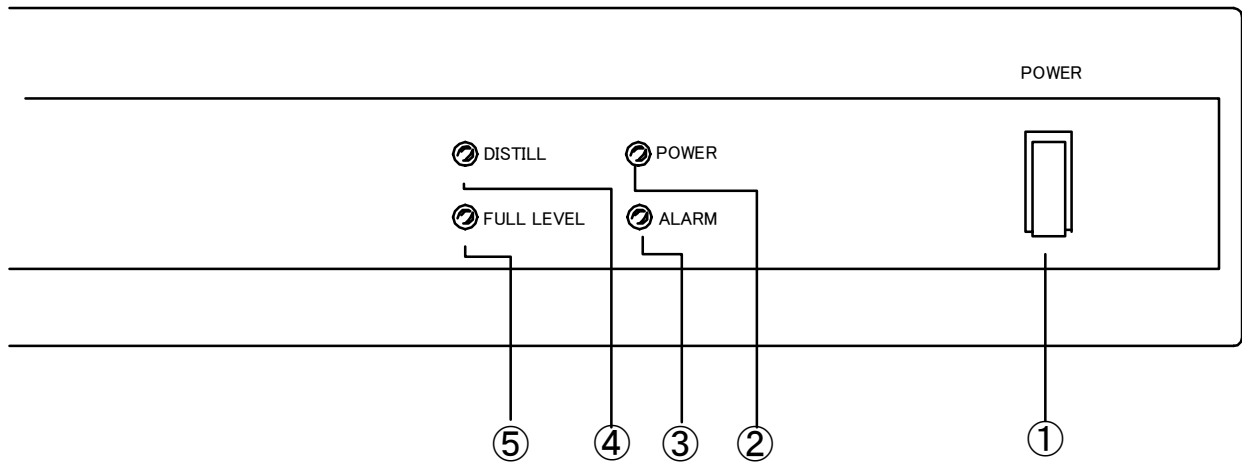

①	Power switch :	Power switch shared by the earth leakage breaker. If the lever is raised, it is ON.
②	Power lamp :	POWER (green): Goes ON when the power switch is ON.
③	Alarm lamp :	ALARM (red): Goes ON when the boiler water level falls.
④	Distillation lamp :	DISTILL (green): Goes ON in distillation (= heater energized).
⑤	Full tank lamp	FULL LEVEL (green): Goes ON when the tank is full. Then, the lamps ③ and ④ are OFF.

**NOTE)** If the boiler water falls below the specified level, the alarm lamp remains ON until the specified level of water is supplied in the boiler after the power switch is turned ON.  
The alarm lamp goes OFF when the specified level is reached and the heater is energized (distillation lamp ON).

# Description and Function of Each Part

## Piping System View

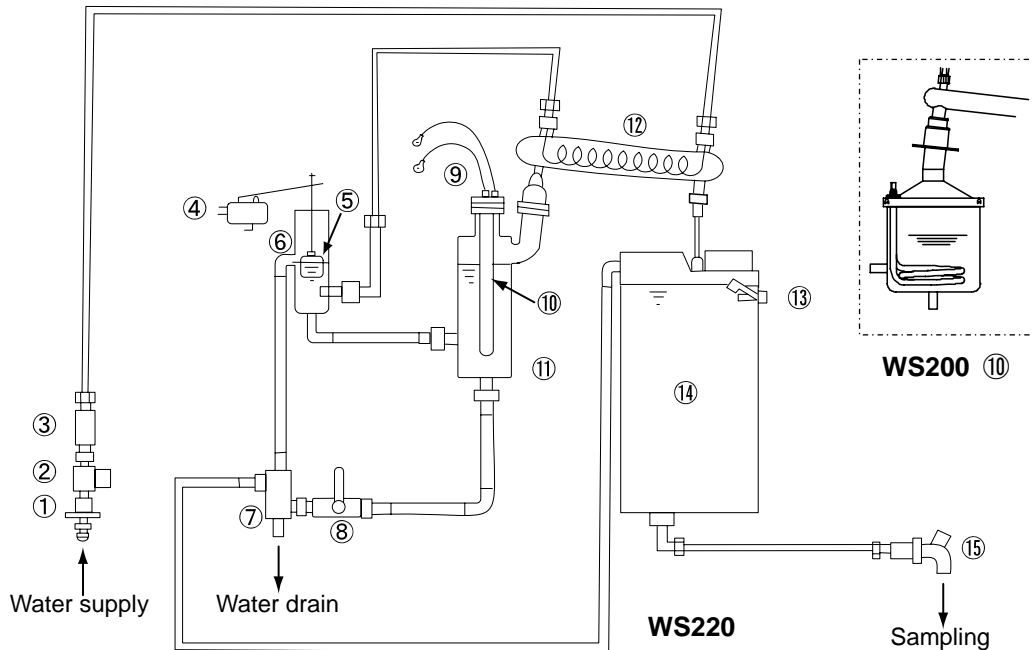

① Water supply port	⑨ Heater
② Solenoid valve	⑩ Heater integument pipe
③ Fixed flow rate valve	⑪ Boiler
④ Micro switch (Heater control)	⑫ Condenser
⑤ Float	⑬ Float switch
⑥ Float tube	⑭ Tank
⑦ Drain port	⑮ Water cock
⑧ Manually cock ( Boiler drain)	

### Mechanism

#### 1) Water Supply (cooling water, boiler water)

Raw water is controlled to a specified flow rate (about 0.8 liter/min.) by the fixed flow rate valve, and heat-exchanged in the condenser ⑫ as the cooling water, and then supplied to the boiler ⑪ via the float tube ⑥, thus overflowing if exceeding the specified level finally to be drained to outside.

#### 2) Distillation

When the boiler ⑪ reaches the specified water level, the float ⑤ in the float tube ⑥ goes up, and detects the water level, and the heater ⑨ is turned ON to start distillation. The water boiled in the boiler turns to steam, cooled/condensed in the condenser ⑫, and then pooled in the tank as distilled water.

#### 3) Full Tank

When the tank ⑭ reaches the specified amount of water of about 20 liter, the float switch ⑬ trips, and the solenoid valve (for supplying water) ② turns OFF, preventing the water supply to the main unit, while the heater ⑨ turns OFF to stop distillation. When any specified amount water has been sampled from the tank, distillation will be restarted.

#### 4) Sampling Water

The distilled water pooled in the tank ⑭ can be sampled by opening the water cock ⑮.

## Connecting the Water Supply Hose

Set the main unit at a level and stable place near the tap and sink.

Keep the space of about 20cm or more in the both sides, over and back of the main unit for radiation. Take out the accessories such as the water supply hose and water drain hose from the packaging material in the bottom.

### Tap Side (See Fig. 1)

1. Slide the sleeve of the socket ③ in the direction of arrow, and the main unit of the connection port can be separated from the hose. At first separate the two components.
2. Loosen the plug ② once by the ring ①.
3. Tighten uniformly the 4 fixing screws ⑤ while pressing softly the packing ⑥ onto the tap flat. If the tap is a chemical water tap, the fixing screws should be adjusted and located at the lowest depth of the tap nipple as shown in the drawing.
4. Turn the plug ② clockwise and tighten it firmly. Thus, the tap and the connection port are sealed with the packing ⑥.
5. While the sleeve is being slid in the direction of arrow, insert the socket ③ into the plug ② firmly. If the sleeve returns when hand comes off, the connection is accomplished.

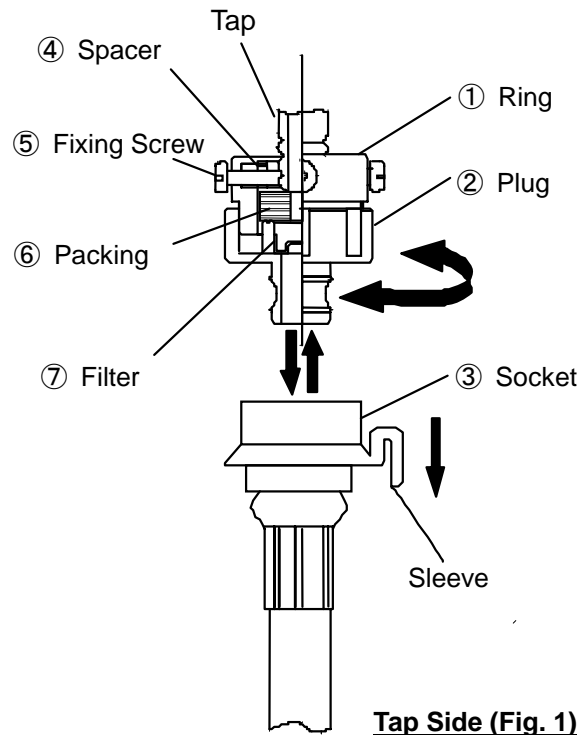

**NOTE)** Ensure that the pressure of water way remains in the range 50 - 500 Kpa including night hours.

### Main Body Side (See Fig. 2)

1. Remove the rubber cap from the plug ①.
2. While the sleeve is being slid in the direction of arrow, insert the socket ② firmly into the plug ① in the main unit side. If the sleeve returns when hand comes off, the connection is accomplished. The socket has a valve in it, and such valve will not open unless the plug is connected, thus preventing the passage of water.

**NOTE)** Be sure to connect the attached hose to the tap at a place where sink is installed (water drain). If no water drain system is available in the tap side, be sure to use "Water supply power unit" in the nonstandard option for safety measure for water leakage.

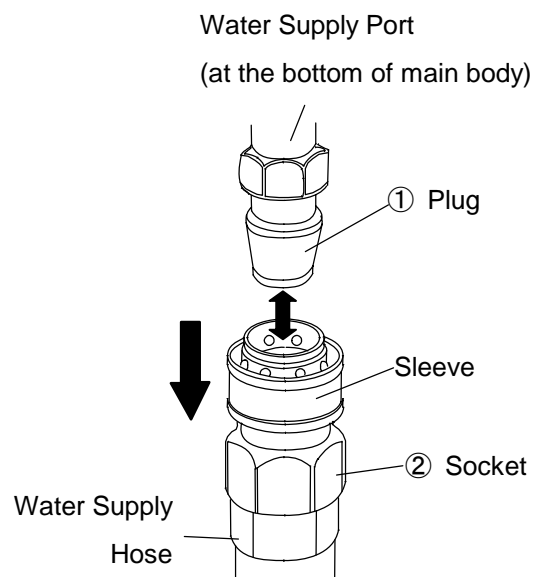

**Main Body Side (Fig. 2)**

## Connecting the Drain Hose

1. Remove the rubber plug from the outlet of the water drain port ②.
2. Route the water drain hose ⑤, and insert it into the water drain port ②. Then tighten them with the attached hose band ⑥ firmly.
3. When discharging the boiler water, the temp of the drained water could exceed 60°C. Worker could be burned. Do not touch such water carelessly. Water should be drained to a place away from the work place.

### NOTE)

- The water drain hose may be routed in from the right/left sides of the main unit. Route such hose in from convenient side.
- Do not wind around the water drain hose, but cut it to the required length for use. Take delicate care to prevent it from being folded, and be sure to place it below the water drain port of the main unit. Any piping possibly causing water pool in the hose or at the outlet of the hose should be avoided, because the resistance in discharging water increases. Flow of water could also be reversed.

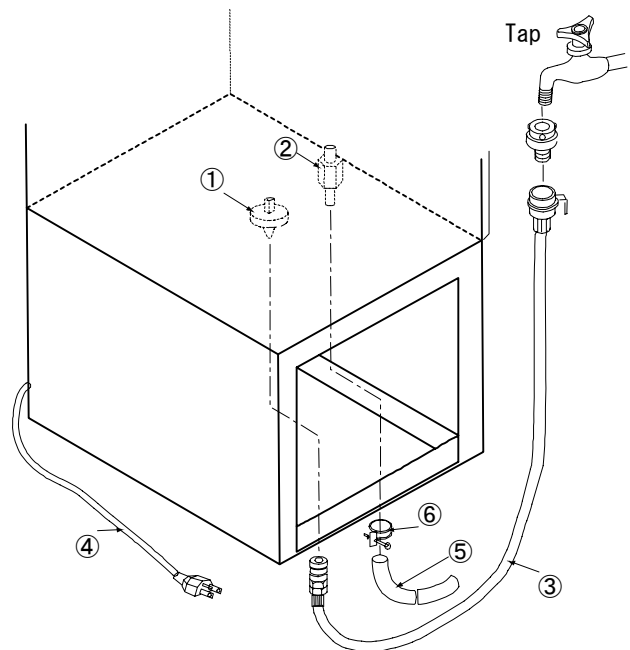

- |                     |                    |
|---------------------|--------------------|
| ① Water supply port | ② Water drain port |
| ③ Water supply hose | ④ Power cable      |
| ⑤ Water drain hose  | ⑥ Hose band        |

## Operation Preparation

Open the front door of the main unit, and remove the rubber rings fixing the micro-switch and the float in the float tube (fixed to prevent the float from coming off in transit). (Be sure to remove this, for non-load combustion is feared.)

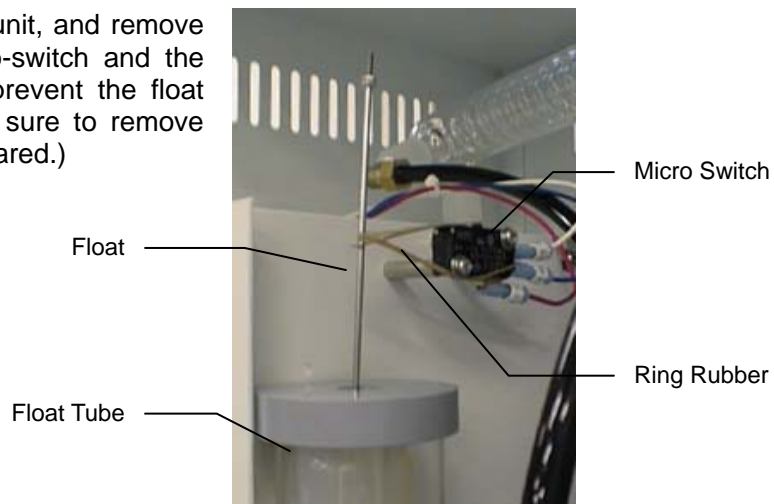

## Operation Method

1. Open the tap.
2. Check if the manual cock for discharging boiler water is closed.
3. Turn ON the power switch (shared by earth leakage breaker) in the front.
4. The distilled water pooled in the tank can be sampled by opening the tap.



## **WARNING!**

### **If a problem occurs**

 If smoke or strange odor should come out of this unit for some reason, turn off the power key right away, and then turn off the circuit breaker and the main power. Immediately contact a service technician for inspection. If this procedure is not followed, fire or electrical shock may result. Never perform repair work yourself, since it is dangerous and not recommended.

### **Substances that cannot be used**

 Never use explosive substances, flammable substances and substances that include explosive or flammable ingredients in this unit. Explosion or fire may occur. (Refer to page27 "List of Dangerous Substances".)

## **CAUTION!**

### **Do not step on this unit**

 Do not step on this unit. It will cause injury if this unit fall down or break.

### **Do not put anything on this unit**

 Do not put anything on this unit. It will cause injury if fall.

### **During a thunder storm**

 During a thunderstorm, turn off the power key immediately, then turn off the circuit breaker and the main power. If this procedure is not followed, fire or electrical shock may be caused.

### **Clean this unit with enough**

 The insides of the boiler, condenser and storage tank are washed previously. However, when using this unit for the first time or after this unit was stopped for a long time, drain about 5 liters of water in an attempt to remove initial impurities.

### **Sampled amount**

 Amount of the distilled water sampled differs more or less according to the minor fluctuations of heater capacity, power voltage or of raw water temp. and the boiler scale deposited on the heater.

### **Pressure of water way**

 The pressure of water way shall always be in the range 50 - 500 Kpa (0.5 - 5kgf/cm<sup>2</sup>). If the pressure of water way is too low, steam could gush out from the condenser due to the shortage of cooling water.

### **Countermeasure for stop operation during night or long-term stop**

 In case of stopping operation during night or long-term, toggle the power switch to "OFF", and also close the tap.

## **CAUTION!**

### **Prevention of freezing**



If it is necessary to use this unit at a cold place in winter, and if the pipe or the water in the boiler could freeze, install an electric lamp (100 - 200W) in the armor of the main unit to prevent freezing. Such lamp to prevent freezing and this unit shall always be energized by different power sources. Such lamp must not be energized via the breaker in this unit.

### **Using well water**



If any well water is used for the raw water, more of residues including scale are deposited in the boiler. Therefore, clean the inside of the boiler more often than the case tap water is used.

### **Characteristics of distilled water**



Distilled water has the following characteristics. However, it is ideal to use the demineralized water immediately after it is distilled and sampled. If, therefore, distilled water has been pooled in the tank for a long time, drain such water once, and then start distillation anew. Substances of low boiling point such as ammonia can be removed, and both electrolytic and non-electrolytic substances can be removed averagely as well. In the manufacturing (condensation and storage) process, however, carbon dioxide gas is absorbed from the atmosphere to produce carbonic acid. So the electric conductivity is worse than ion exchanged water; about  $2$  to  $3 \times 10^{-4} \text{S/m}$  ( $2$  to  $3 \mu \text{S/cm}$ )  $25^\circ\text{C}$ . This is a weak acidity (PH5 to 6). To remove the dissolved gases (oxygen and carbon dioxide gas) in the demineralized water, see the item "2 - Common Items, (8) Water" in JIS K 0102 (How to Test Industrial Waste Water).

### **Recovery of power failure**



When power is supplied after a power failure, the device automatically starts operation again with the same state as just before the power failure. It is danger that the device starts unattached operation after a power failure. We recommend for you to turn off the switch of this unit if a power failure occurs during operation.

## Daily Inspection and Maintenance

For the safety use of this unit, please perform the daily inspection and maintenance without fail. Since this unit distills the city water directly, scale is deposited in the boiler extremely. Therefore, maintenance and checks are mainly planned to remove such boiler scale.

### Reference for maintenance

Maintenance/check items	Reference for timing	Remarks
Washing Distiller	3 months	Wash the distiller more often in case the quality of raw water is not good.
Washing water supply hose filter	6 months	
Replacement of hoses	2 years	Connections shall be checked once per month.
Replacement of flow washers	If the amount of cooling water decreases and if steam comes out from the condenser or float tube.	The flow washer (rubber) in the fixed flow rate valve deteriorates in about 2 years. In such a case, ask for services.

### **WARNING!**

- Disconnect the power cable from the power source when doing an inspection or maintenance unless needed.
- Perform the daily inspection and maintenance after returning the temperature of this unit to the normal one.
- Do not disassemble this unit.

### **CAUTION!**

#### Main unit maintenance

- Use a well-drained soft cloth to wipe dirt on this unit. Do not use benzene, thinner or cleanser for wiping. Do not scrub this unit. Deformation, deterioration or color change may result in.

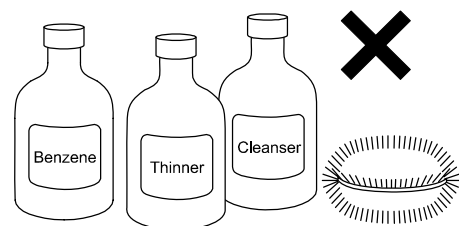

#### Monthly maintenance

- Check the earth leakage breaker function.
  1. Connect the power cord.
  2. Turn the breaker on.
  3. Push the red test switch by a ballpoint pen etc.
  4. If there is no problem, the earth leakage breaker will be turned off.

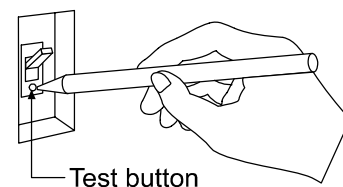

For any questions, contact the dealer who you purchased this unit from, or the nearest sales division in our company.

## Washing Distiller

### 1. Water Drained from Boiler

Water in the boiler is condensed as the distillation continues, thus promoting the deposition of boiler scale. To prevent this, open the front door once or twice daily (after every 5 - 8 hours of distillation), and drain water via the boiler water drain cock in the front. After completing the drain of water, turn ON the power switch to start supplying water. Close the cock after discharging water for 2 - 3 min. This washes away the scale from the pipes effectively.

### 2. Washing Distiller

If large amount of boiler scale is deposited in the boiler or float tube, malfunction (non-load combustion) could result. Check the unit once per month. Wash the boiler once in about 3 months. Do this more often according to the water quality and operating hours.

#### Removal of Distiller

1. Turn OFF the power switch.
2. Open the front door.
3. Open the manual cock to drain the water from the boiler.

### 2-A) WS200 (See Fig. 5 on the next page.)

1. Raise the cover (Teflon tube) ⑧ for the heater terminal ⑫ on top of the boiler, and remove the lead wire from the heater ④ by using Phillips screwdriver. In doing this, take care not to drop the heater lead wire or terminal cover in the back until it is installed next.
2. Pull off the metal piece (same as ⑥ in WS220) fixing the boiler ① and condenser by loosening the 3 knurled screws (same as ⑦ in WS220).
3. Remove the silicone hoses and cap nuts from the boiler water drain port ⑨ and the boiler water supply port ⑩. In doing this, pay attention to the dripping water.
4. When the screws fixing the boiler are removed by using Phillips screwdriver, the distiller (boiler) can be removed.

**NOTE)** Packing is provided between the condenser and boiler. Store this with great care.

### 2-B) WS220 (See Figs. 5 on the next page and 5-1 on this page.)

The heater terminal ⑫ is connected to the terminal block a in the upper frame. Remove the locking screw c, terminal cover b and locking screw d by using Phillips screwdriver, and remove the lead wire of the heater.

Take the subsequent steps the same way as in WS200.

#### NOTE)

- Packing is used in each connection. Take care not to lose these packing when removing components.
- Glass components and heater are easily damaged. Handle these things with great care. Do not try to fold or pull the heater or lead wire more than necessary, either.

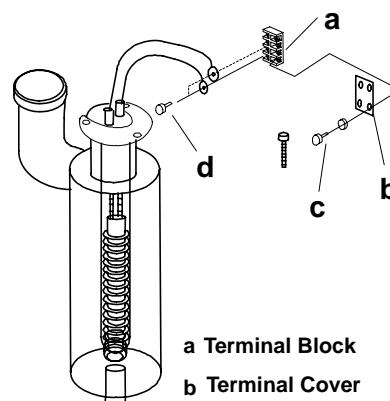

**Fig. 5-1**

- a Terminal Block
- b Terminal Cover
- c Locking Screw (for Locking Terminal Cover)
- d Locking Screw (for Locking Lead Wire)

Washing Distiller

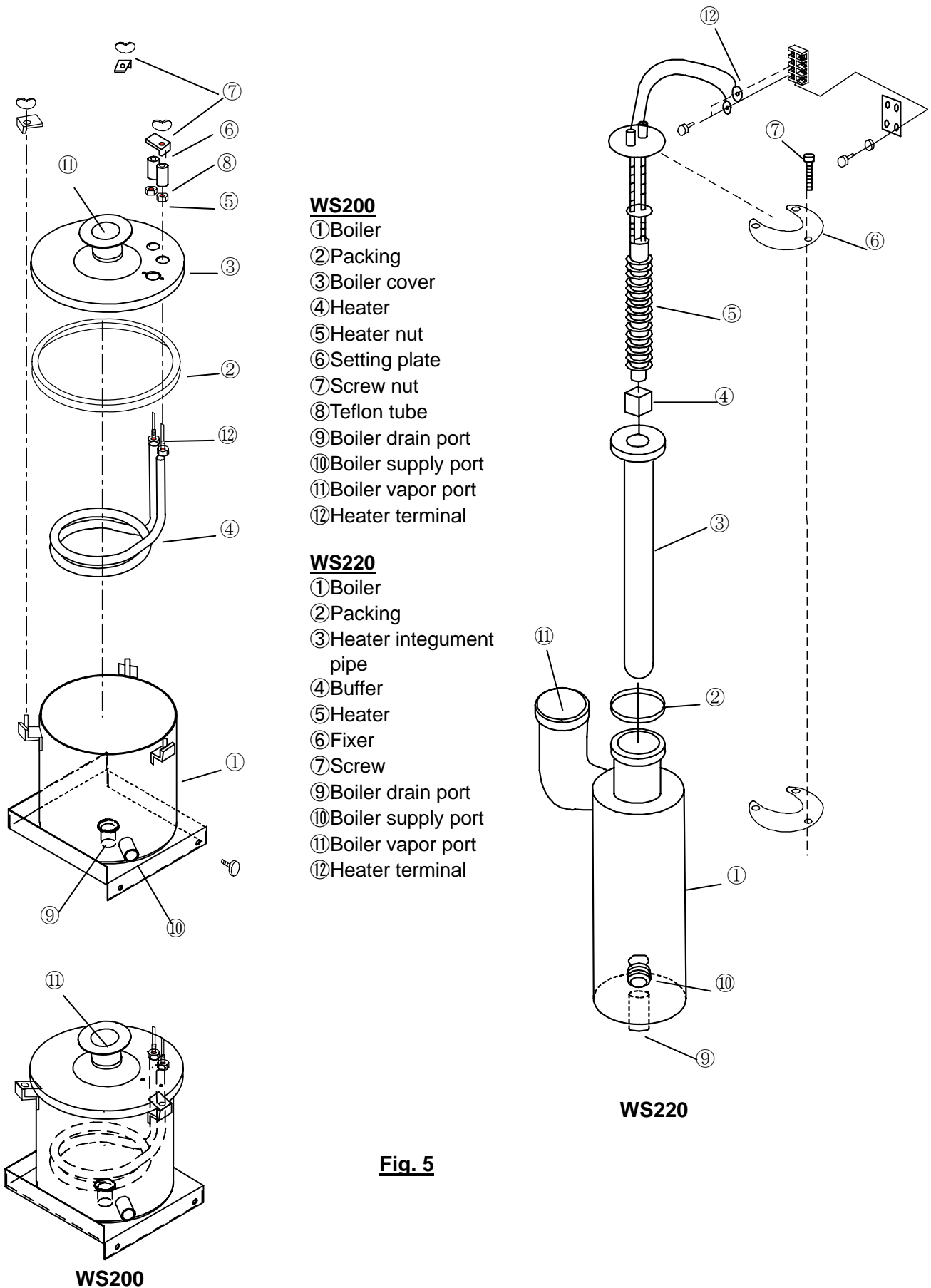

Fig. 5

## Washing Method

### 1. Adjustment of Washing Solution

Prepare about 2 liters of hot water at 50 - 60°C for WS200, and about 1.5 liters for WS220.

Add about 200 g (WS200) or 150 g (WS220) of the attached scale-washing agent to this hot water, and stir thoroughly (standard: 8 - 10%).

### 2. Washing Method

1. Wash the boiler ① with water. Never wet the heater terminal with water.
2. Insert the attached rubber plugs (2 pcs) into the boiler water drain port ⑨ and the boiler water supply port ⑩.
3. Put the boiler in the bucket, etc., and stand it almost vertical, and then supply the washing solution prepared in "1. Adjustment of Washing Solution" into the boiler by way of the boiler steam port ⑪. Most of the boiler scale will be eliminated in 4 to 5 hours. If large amount of scale is deposited, add the washing solution newly, and repeat washing, or tray washing with brush.
4. When the washing of scale is completed, drain the solution (First, neutralize the solution with the counteragent such as sodium hydroxide, and then drain), and remove the rubber plugs. Next, wash this with water thoroughly until it gets neutral. In doing this, too, take care so that the heater terminal may not get wet with water.

#### NOTE)

- Wash the boiler and heater as soon as possible. The more scale is deposited, the more difficult it is to remove such scale. Amount of distilled water sampled may be reduced, or the heater may be damaged.
- If the condenser or float tube is fouled badly, wash it similarly. As in washing the boiler, supply the washing solution 4 to 5 hours before. Most of the scale will be eliminated.
- After completing the washing, drain the washing solution outside, and neutralize by using counteragent. In such neutralizing operation, use pH test paper, etc. to check neutrality (main ingredient: sulfamic acid).
- In storing this washing agent, seal the container to avoid high temp. and high humidity, and store it at a dark place.
- When handling this washing agent, wear protective tools (gloves, mask, goggles, etc.).
- If any part of human body comes in contact with the washing agent, wash such part with clean water thoroughly.
- Empty container must not be used to contain drinks.
- Since this causes rice plant to wither, do not flow the washing agents into the agricultural waterway of paddy fields.

### 3. Installation of Distiller

Install the distiller in the reversed order of removal procedure after wiping off the water from the outside of the boiler. Pay appropriate attention to the following points:

- If any locking screw connecting heater is loose, burning accident may result. Take appropriate care even after connection.
- Check if the hose and packing are inserted into each joint.
- Check if the boiler water drain cock is closed.

## Replacement of Hose

### 1. Washing Water Supply Hose Filter

1. After closing the water cock, separate the connection port from the hose side by one-touch joint.
2. Remove the plug ② from the ring ①, and wash the filter ⑦ inserted in the plug with city water.
3. If clogged badly, remove the filter by using the flat side of pencil, and wash it by using brush, etc.

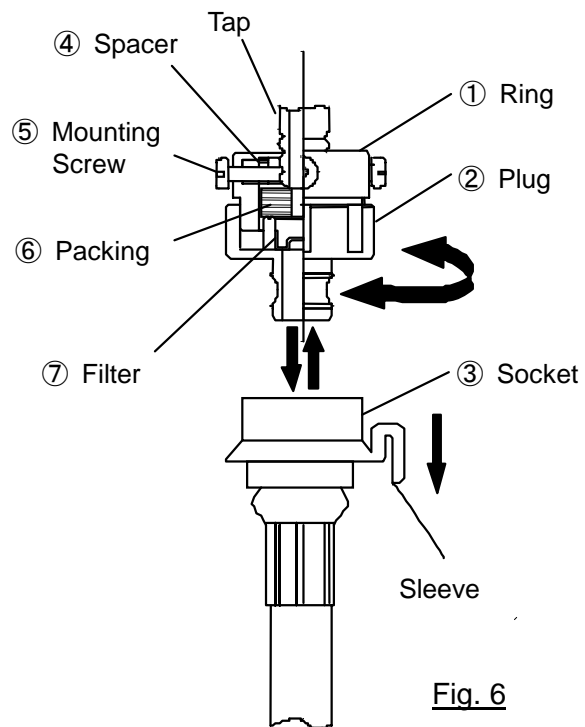

### 2. Replacement of Hose

Be sure to use the replacement hoses specified by Yamato Scientific.

Replace the pressure-resistant hoses (black and milky white hoses) used in the unit in the following procedure:

1. Remove the cap nut, and pull off the hose from the connector.
2. Replace the cap nut and sleeve to the new hose. Cut the top of the hose as perpendicularly as possible.
3. Insert the hose to the depth of the connector, and tighten the cap nut firmly by way of the sleeve.

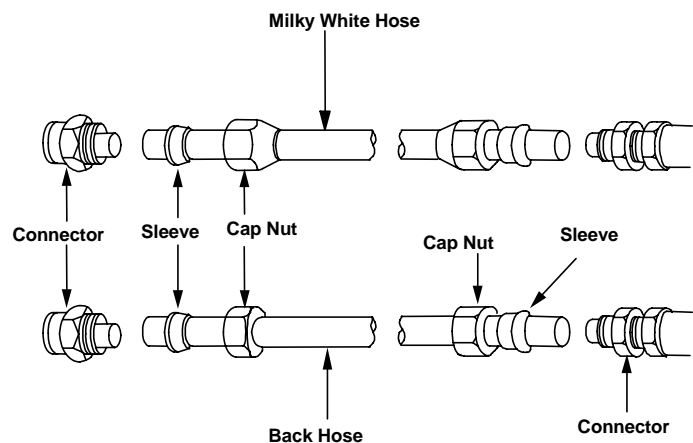

## Replacement of Heater

### 1. WS200 (See Fig. 5 in Page 17)

1. Turn OFF the power switch.
2. Open the front door.
3. Open the manual cock, and drain water from the boiler.

According to Page 16 "Washing Distiller" remove the heater of WS200 along with the distiller (boiler ①), and remove the mounting plate ⑥, butterfly nut ⑦ and boiler cover ③ sequentially, and then remove the heater.

### 2. WS220 (See Fig. 5 in Page 17 and Fig. 5-1 in Page 16)

1. Turn OFF the power switch.
2. Open the front door.
3. Open the manual cock, and drain water from the boiler.
4. Remove the locking screws (2 pcs) from the terminal block a fixed in the upper frame of the main unit, and remove the terminal block cover b. Remove the screw d fixing the lead wire of the heater by using Phillips screwdriver, and then remove the lead wire.
5. Pull off the metal press ⑥ fixing the distiller (boiler ①), outer tube of heater ③ and heater ⑤ by loosening the knurled screws (3 pcs) ⑦.
6. Remove the cover fixed on the frame ceiling by removing the locking screws (2 pcs).
7. Heater can be unloaded by itself, not with distiller, from the hole on top of the frame.



## When not using this unit for long term / When disposing

### **CAUTION!**

#### When not using this unit for long term...

- Turn off the power and disconnect the power cord.

### **WARNING!**

#### When disposing...

- Keep out of reach of children.
- Remove the driving parts.
- Treat as large trash.

### **Environmental protection should be considered**

We request you to disassemble this unit as possible and recycle the reusable parts considering to the environmental protection. The feature components of this unit and materials used are listed below.

Component Name	Material		
<b>Main Components of Exterior</b>			
Exterior	Made of iron, bonded steel plate, melamine resin baking finish		
Door	Made of iron, bonded steel plate, melamine resin baking finish		
Leg	Made of iron, bonded steel plate, melamine resin baking finish		
<b>Main Components of Distill/Condense System</b>			
Boiler (WS200)	Stainless steel plate SUS 304		
Boiler cover (WS200)	Stainless steel plate SUS 304		
Heater (WS200)	Copper pipe, Iron-chrome wire, and others		
Boiler packing	Silicon rubber		
Boiler (WS220)	Hard glass		
Heater integument pipe (WS220)	Quartz glass		
Bobbin heater (WS220)	Porcelain, Iron-chrome wire		
Condenser	Hard glass		
Float tube	Hard glass		
Float tube cover	PVC		
Float	P.P		
Float shaft	Stainless steel SUS 304		
Condenser	Brass		
<b>Main Components of Tank Section</b>			
Distilled water tank	Polyethylene		
Water cock	Polyacetal		
<b>Main Components of Piping System</b>			
Water supply port, Drain port	Brass	Pipe joint (resin)	P.P
Fixed flow rate valve	Brass, and others	Hose (black/thin)	Nylon
Drain cock	Brass, and others	Hose (black/thick)	Ethylene propylene
Pipe joint (metal)	Brass	Hose (transparent)	Silicon rubber

## Trouble Shooting

Condition	Possible Causes
Power lamp on the control panel does not light on when turning on the power switch.	<ul style="list-style-type: none"><li>• Power plug is not connected to the receptacle correctly.</li><li>• Power failure.</li></ul>
No water is supplied.	<ul style="list-style-type: none"><li>• Defects in the raw water supply solenoid valve.</li><li>• Insufficient pressure of water way or cut-off of water.</li></ul>
Water supply is not stopped.	<ul style="list-style-type: none"><li>• Defects in the float switch.</li><li>• Defects in the raw water supply solenoid valve.</li></ul>
No water is supplied to boiler.	<ul style="list-style-type: none"><li>• Defect of float switch.</li><li>• Defect of boiler water supply solenoid valve.</li></ul>
Heater does not turn on.	<ul style="list-style-type: none"><li>• Defect of float switch.</li><li>• Heater disconnection.</li></ul>
Distillation does not stop.	<ul style="list-style-type: none"><li>• Defect of float switch.</li></ul>

## When power failure occurs...

- When power is supplied after a power failure, the device automatically starts operation again with the same state as just before the power failure. It is danger that the device starts unattached operation after a power failure.
- We recommend for you to turn off the switch of device if a power failure occurs during operation.

**In the case if the error other than listed above occurred, turn off the power switch and primary power source immediately. Contact the shop of your purchase or nearest Yamato Scientific Service Office.**

### In Case of Request for Repair

If the failure occurs, stop the operation, turn OFF the power switch, and unplug the power plug. Please contact the sales agency that this unit was purchased, or the Yamato Scientific's sales office.

#### < Check following items before contact >

- ◆ Model Name of Product
  - ◆ Production Number
  - ◆ Purchase Date
  - ◆ About Trouble (in detail as possible)
- } See the production plate attached to this unit.

### Minimum Retention Period of Performance Parts for Repair

The minimum retention period of performance parts for repair of this unit is 7 years after discontinuance of this unit.

The "performance part for repair" is the part that is required to maintain this unit.

Model		WS200	WS220
<i>Performance</i>	Collecting method	Distillation	
	Sampled pure water	Distilled water	
	Quantity of distilled water	Approx. 1.8L/h	
<i>Configuration</i>	Distiller	Boiler	Stainless steel (SUS 304)
		Condenser	Super hard glass
	Heater	Pipe heater	Set in quartz glass integument pipe
	Distilled water storage tank	Made of polyethylene, 20L	
<i>Standard</i>	Power supply	100V AC single phase 50/60Hz 15A	
	External dimensions (W × D × H)	500 × 400 × 975 mm	
	Weight	Approx. 30kg	
<i>Attached accessories</i>	Water supply hose (Connect unit is attached) : 2m, Water drain hose (Hose band is attached) : 2m, Scale washing agent : 1kg, Rubber stopcock (for washing distiller) : 2pcs, Instruction manual		
<i>Expendables</i>	Scale washing agent, Heater		
<i>Attached mechanism</i>	Auto adjustment of cooling water volume, Prevention of baking heater with no load, Earth leakage breaker		

## Optional accessories

Product Code	Name/Specification
253686	Water supply port unit
253176	Frame (AS22) / External dimensions (set with WS200/220) : W576 × D416 × H1835 mm

# Wiring Diagram

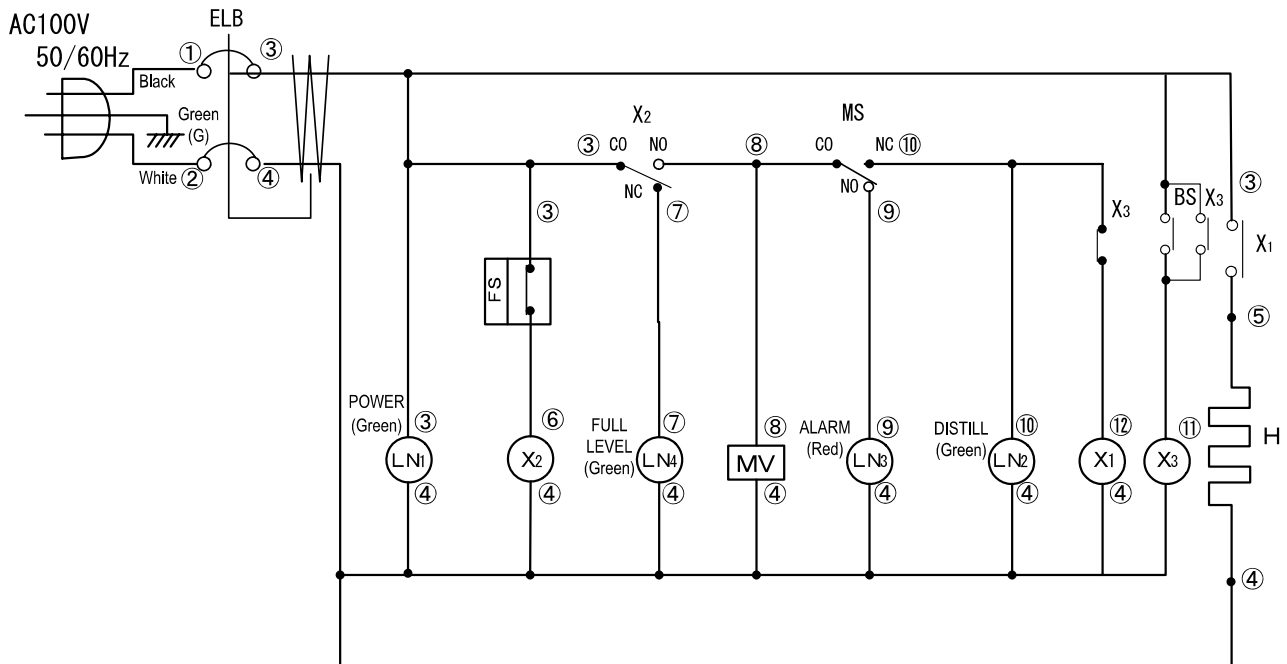

Symbol	Part name	Symbol	Part name
ELB	Earth leakage breaker	X <sub>1</sub>	Relay (for heater)
LN <sub>1</sub>	Power lamp	X <sub>2</sub>	Relay (for water level of tank)
LN <sub>2</sub>	Distill lamp	MS	Micro switch (for water level of boiler)
LN <sub>3</sub>	Alarm lamp	FS	Float switch
LN <sub>4</sub>	Full level lamp	MV	Water supply solenoid valve
BS	Bimetal thermostat	H	Heater

# Replacement Parts Table

## Common Use Parts

Part Name	Code No.	Specification	Manufacturer
Solenoid valve	3020076019	AB21022A AC100V	CKD
Fixed flow rate valve	3220016004	RSP-10-8-0.8L	Keihin
Flow washer for fixed flow rate valve (*)	322001600A	0.8L	Keihin
Ball valve	3150030001	BSN-00-08 PT1/4	Miyairi Valve
Micro switch	253044-176	VX-53-1A3 secondary processing	Miyairi Valve
Condenser	253003-215	Super hard glass	Miyairi Valve
Packing (for condenser)	7120016050	Silicon $\phi 60 \times \phi 44 \times t 2$	Miyairi Valve
Distilled water tank	253045-162	Hard polyethylene	Miyairi Valve
Float switch	20400300003	FR-1-100	Tokyo Seigyo
Earth leakage breaker	2060050002	BJS203	Matsushita
Terminal block	2070066001	FD-06-N30-4P 250 tab ABC	Kohwa
Lamp	2090066012	BN-9E-W/R AC100V (green)	Satoh Parts
Lamp	2090066018	BN-9E-W/R AC100V (red)	Satoh Parts
Relay	2050000019	AHE-1254	Matsushita
Relay	LT00029307	AP5514F	Matsushita
Water cock	3270016001	Polyacetal	Opera
Scale washing agent (*)	8190010001	Orgazol 10	Organo
Bimetal thermostat	WA33000110	TH-53F580FS 110°C	Fuji Controls
Relay	2050080002	AP3124K	Matsushita

## WS200

Float tube	WS200-30130	Super hard glass	Yamato Scientific
Boiler	253045-146	SUS304	Yamato Scientific
Heater	253045-149	1.5KW AC100V	Yamato Scientific
Packing (for boiler)	253045-150	Silicon	Yamato Scientific

## WS220

Nut (for boiler)	253044-153	Teflon	Yamato Scientific
Boiler	253046-146	Super hard glass	Yamato Scientific
Heater integument pipe	253044-151	Quartz glass	Yamato Scientific
Heater (*)	253046-149	Bobbin type 1.5KW AC100V	Yamato Scientific
Packing (for heater)	7120016073	Teflon	Yamato Scientific
Kao-wool	6030036001	20 × 25 × t30	Yamato Scientific
L-pipe	253046-155	Super hard glass	Yamato Scientific
Heater terminal block	2070146001	ML-17652P (with double screw cover)	Satoh Parts
Float tube	WS220-30080	Super hard glass	Yamato Scientific

\*:Expendables

## List of Dangerous Substances



Never use explosive substances, flammable substances and substances that include explosive or flammable ingredients in this unit.

### EXPLOSIVE

<b>EXPLOSIVE:</b>	Ethylene glycol dinitrate (nitro glycol), Glycerin trinitrate (nitroglycerine), Cellulose nitrate (nitrocellulose), and other explosive nitrate esters
	Trinitrobenzene, Trinitrotoluene, Trinitrophenol (picric acid), and other explosive nitro compounds
	Acetyl hidroperoxide (peracetic acid), Methyl ethyl ketone peroxide, Benzyl peroxide, and other organic peroxides

### FLAMMABLE

<b>IGNITING:</b>	Lithium (metal), Potassium (metal), Sodium (metal), Yellow phosphorus, Phosphorus sulfide, Red phosphorus, Celluloid compounds, Calcium carbide, Lime phosphate, Magnesium (powder), Aluminum (powder), Powder of metals other than magnesium and aluminum, Sodium hydrosulfite
<b>OXIDIZING:</b>	Potassium chlorate, Sodium chlorate, Ammonium chlorate, and other chlorate
	Potassium perchlorate, Sodium perchlorate, Ammonium perchlorate, and other perchlorate
	Potassium peroxide, Sodium peroxide, Barium peroxide, and other inorganic peroxide
	Potassium nitrate, Sodium nitrate, Ammonium nitrate, and other nitrate
	Sodium chlorite and other chlorites
	Calcium hypochlorite and other hypochlorites
<b>INFLAMMABLE LIQUID:</b>	Ethyl ether, Gasoline, Acetaldehyde, Propylene chloride, Carbon disulfide, and other flammable substances having a flash point of lower than -30°C
	Normal hexane, ethylene oxide, acetone, benzene, methyl ethyl ketone, and other flammable substances having a flash point of -30°C or higher but lower than 0°C
	Methanol, Ethanol, Xylene, Pentyl acetate (amyl acetate), and other flammable substances having a flash point of 0°C or higher but lower than 30°C
	Kerosene, Light oil (gas oil), Oil of turpentine, Isopentyl alcohol (isoamyl alcohol), Acetic acid, and other flammable substances having a flash point of 30°C or higher but lower than 65°C
<b>FLAMMABLE GAS:</b>	Hydrogen, Acetylene, Ethylene, Methane, Propane, Butane, and other flammable substances which assume a gaseous state at 15°C and 1 atm

(Source: Appendix Table 1 of Article 6 of the Industrial Safety and Health Order in Japan)

## Responsibility

Please follow the instructions in this document when using this unit. Yamato Scientific has no responsibility for the accidents or breakdown of device if it is used with a failure to comply. Never conduct what this document forbids. Unexpected accidents or breakdown may result in.

## Note

- ◆ The contents of this document may be changed in future without notice.
- ◆ Any books with missing pages or disorderly binding may be replaced.

Instruction Manual for

**Water Purifier, Auto Still  
Model WS200/220**

First Edition Feb. 27, 2001

Revision Oct. 20, 2008

---

**Yamato Scientific Co., Ltd.**

2-1-6 Nihonbashi Honcho, Chuo-ku,  
Tokyo, 103-8432, Japan

<http://www.yamato-net.co.jp>